



**PRODUCT PROFILE TELESCOPIC CYLINDERS
ALPHA FC DOUBLE ACTING**



Lower dead weight
= Higher payload



Faster tipping and lowering
= Shorter cycle time



Lower oil & fuel consumption
= Environmental friendly



Most efficient
= Productive & profitable



Double chrome
= Increased corrosion resistance



Safer and more reliable
= Reduced downtime



Longer service intervals
= Increased operating time



Cost effective
= Can reduce operating costs

Coast-to-Coast HYVA stocked warehouse & distributors
HYVA direct field sales team & after sales support
2 year factory warranty on all new cylinders

ADVANTAGES & BENEFITS



Premium Quality Steel

- Highest pressures available to the industry (Up to 3626 psi)
- Rugged durability, large wall thickness = increased strength

All stages double hard chrome

- No corrosion, longer seal life

Premium cylinder design

- Low cylinder weight = more load capacity
- Faster cycle time
- Low oil volume requirement = Less oil expense

Premium internal seals

- Improved sealing in all climates
- Low maintenance – no adjusting nuts

Improved dust cover design

- Improved fit and coverage
- Better protection from debris & elements

FC - ALPHA SERIES FRONT END CYLINDER WITH COVER DA RANGE

Article number	US type	Weight	K*	Total	A1/2	B1/2	C	D	H*	I	J	S	T	U	V	W	X	Last stage	Stroke	Max
		LBS	(")	Gallon	(")	(")	(")	(")	(")	(")	(")	(")	(")	(")	(")	(")	(")	(")	(")	(")
70553091	FC A4.5-3-80-K6-DA-DHC	223	5.51	4.8	7.91/7.91	5.79/6.26	5.08	6.61	43.35	2.17	2.99	3.46	1 1/16	1.87	2	1.87	1.26	2.83	79.90	3626
70553111	FC A4.5-3-91-K6-DA-DHC	238	5.51	5.5	7.91/7.91	5.79/6.26	5.08	6.61	46.50	2.17	2.99	3.46	1 1/16	1.87	2	1.87	1.26	2.83	90.90	3626
70553131	FC A4.5-3-98-K6-DA-DHC	238	5.51	5.5	7.91/7.91	5.79/6.26	5.08	6.61	46.50	2.17	2.99	3.46	1 1/16	1.87	2	1.87	1.26	2.83	98.20	3626
70554121	FC A5.5-3-110-K6-DA-DHC	328	6.38	9.5	9.02/8.82	7.01/7.09	5.91	7.63	52.28	2.56	3.50	4.02	1 1/16	1.87	2	1.87	1.26	3.58	110.20	3626
70554151	FC A5.5-3-120-K6-DA-DHC	346	6.38	8.7	9.02/8.82	7.01/7.09	5.91	7.63	55.04	2.56	3.50	4.02	1 1/16	1.87	2	1.87	1.26	3.58	120.10	3626
70554171	FC A5.5-3-125-K6-DA-DHC	346	6.38	10.6	9.02/8.82	7.01/7.09	5.91	7.63	55.04	2.56	3.50	4.02	1 1/16	1.87	2	1.87	1.26	3.58	125.00	3626
70554191	FC A5.5-3-135-K6-DA-DHC	364	6.38	11.4	9.02/8.82	7.01/7.09	5.91	7.63	58.58	2.56	3.50	4.02	1 1/16	1.87	2	1.87	1.26	3.58	135.00	3626
70555201	FC A6.5-3-125-K8-DA-DHC	423	7.64	14.5	10.20/9.76	7.91/7.91	6.69	8.62	55.31	2.56	3.74	4.41	1 5/16	2.25	2	2.25	1.50	4.33	125.00	3626
70555241	FC A6.5-3-140-K8-DA-DHC	456	7.64	16.1	10.20/9.76	7.91/7.91	6.69	8.62	60.04	2.56	3.74	4.41	1 5/16	2.25	2	2.25	1.50	4.33	139.80	3626
70555281	FC A6.5-4-150-K8-DA-DHC	441	7.64	14.5	10.20/9.76	7.91/7.91	6.69	8.62	52.17	2.56	3.74	4.41	1 5/16	2.25	2	2.25	1.50	3.58	150.00	3626
70555321	FC A6.5-4-155-K8-DA-DHC	441	7.64	14.5	10.20/9.76	7.91/7.91	6.69	8.62	52.17	2.56	3.74	4.41	1 5/16	2.25	2	2.25	1.50	3.58	155.10	3626
70555361	FC A6.5-4-167-K8-DA-DHC	463	7.64	15.9	10.20/9.76	7.91/7.91	6.69	8.62	55.31	2.56	3.74	4.41	1 5/16	2.25	2	2.25	1.50	3.58	166.90	3626

*Includes 0.79" of pullout on piston (min -0.2", max +1.18").

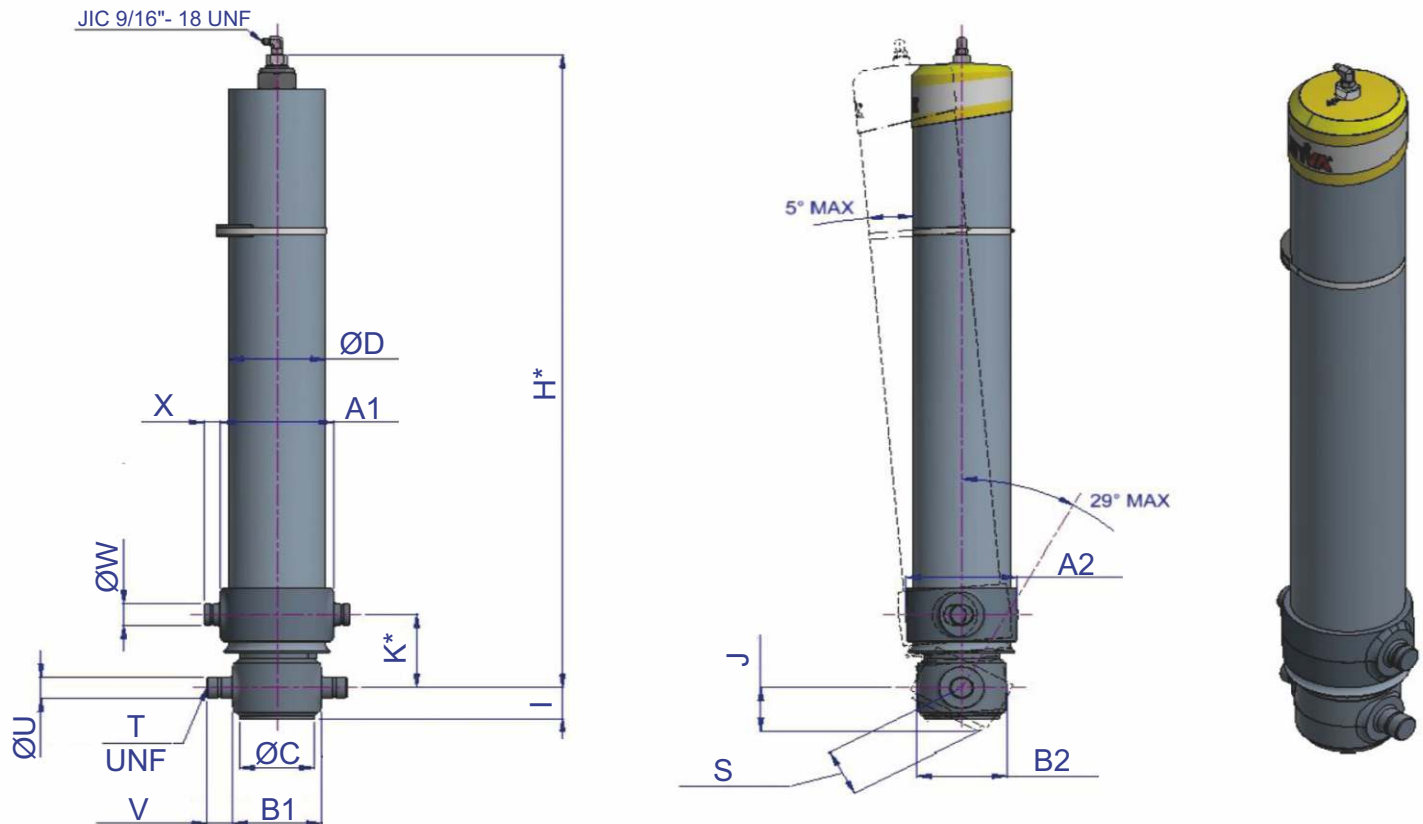

110 countries
+3,500 employees
20,000 customers
+30 subsidiaries
12 production facilities



Hyva is a leading provider of innovative and highly efficient transport solutions for commercial vehicles used in transport, construction, mining, materials handling and environmental service industries.

Founded in 1979 in the Netherlands, the company has a global presence with more than 30 wholly owned subsidiaries, extraordinary service coverage and 12 manufacturing facilities in Brazil, China, Europe and India.

For more information on Hyva, please visit www.hyva.com

or follow us on:



Hyva Corporation
864 Lively Blvd,
Wood Dale, Illinois 60191, USA
Phone: +1-630-227-9020
Fax: +1-630-227-9029
salesusa@hyva.com
www.hyva.com



ISO 9001 • ISO 14001

**Quality and
environmental certified**

DEALER STAMP