

## 1. MEASURE THE NECK - 2"

- Insert the head of the Kingpin through the large opening of the small slot. Locate the gage between the shoulder and the head of the Kingpin.
- Slide the gage toward the small end. The number stamped on the gage at the center of the Kingpin indicates the dimension (see figure 1).
- The Kingpin should be replaced when, at any orientation, the Kingpin reaches the end of the slot (1-7/8" diameter).

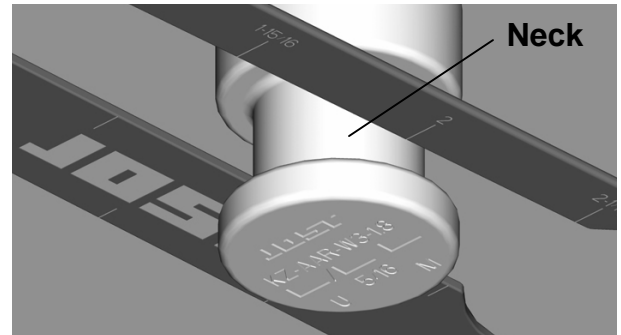

FIGURE 1

## 2. MEASURE THE SHOULDER - 2-7/8"

- Repeat the above procedure using the large slot on the shoulder of the Kingpin (see figure 2).
- Replace if the Kingpin reaches the end of the slot (2-3/4" diameter).

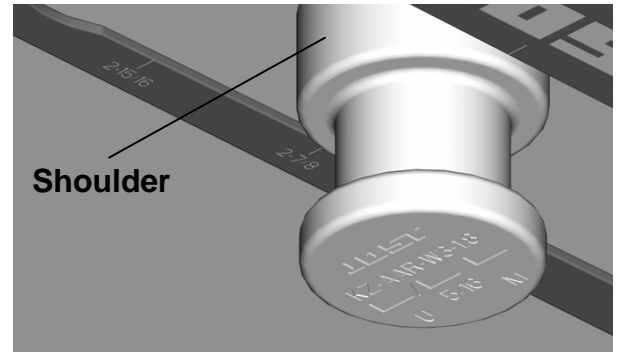

FIGURE 2

## 3. MEASURE THE KINGPIN LENGTH

The Kingpin is the proper length if the "MAX" end engages and the "MIN" end does not engage as shown below.

**Important:** Be sure to hold the gage edge flat to the upper coupler. Check both the "MAX" end and the "MIN" end as shown in figures 3 and 4.

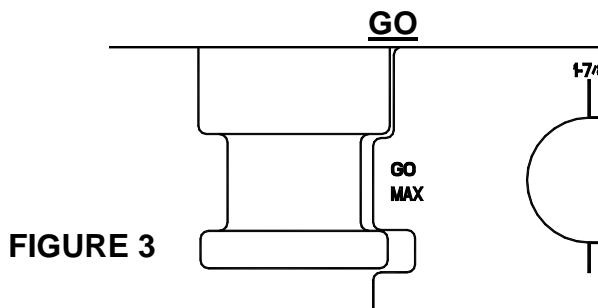

FIGURE 3

**THE "MAX" END SHOULD ALWAYS ENGAGE THE KINGPIN.**

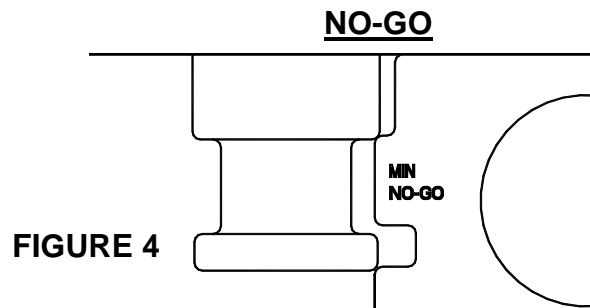

FIGURE 4

**THE "MIN" END SHOULD NEVER ENGAGE THE KINGPIN.**

The right to alter specifications is reserved.