



A440 Magnum Series Landing Gear

Design Features

- Elevating screw is fully encased in a grease tube.
- Legs are completely sealed and all shafts have seals to keep moisture out.
- Double "D" style shaft allows crank force to go directly into the gearbox, not torquing the bolt.
- Gearbox is completely filled with low temperature grease.
- Austempered ductile iron gears will not wear out.
- 10 bolt mounting pattern adds mounting rigidity.
- Reinforcing strap at the bottom of the upper housing for added strength.

Capacities & Ratings

Maximum Static Load Rating*
170,000 lbs

Rated Lift Capacity**:
62,500

Side Load Capacity*:
33,000 per set

*When properly braced on a trailer.

**With 100ft-lbs input torque.

Gear Ratio

Low Gear: 32 Turns = 1" Travel
High Gear: 3.5 Turns = 1" Travel



High Gear

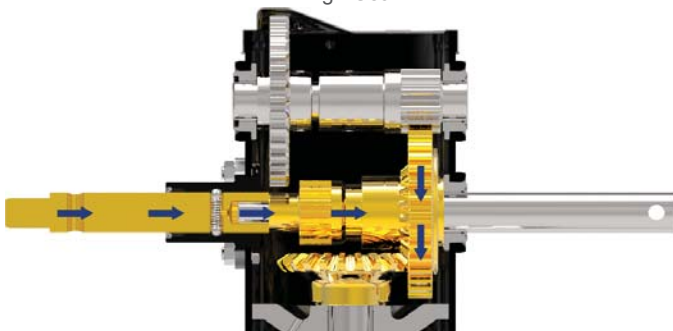

Low Gear

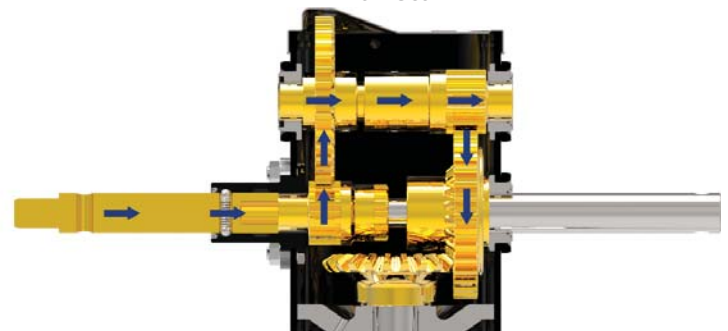

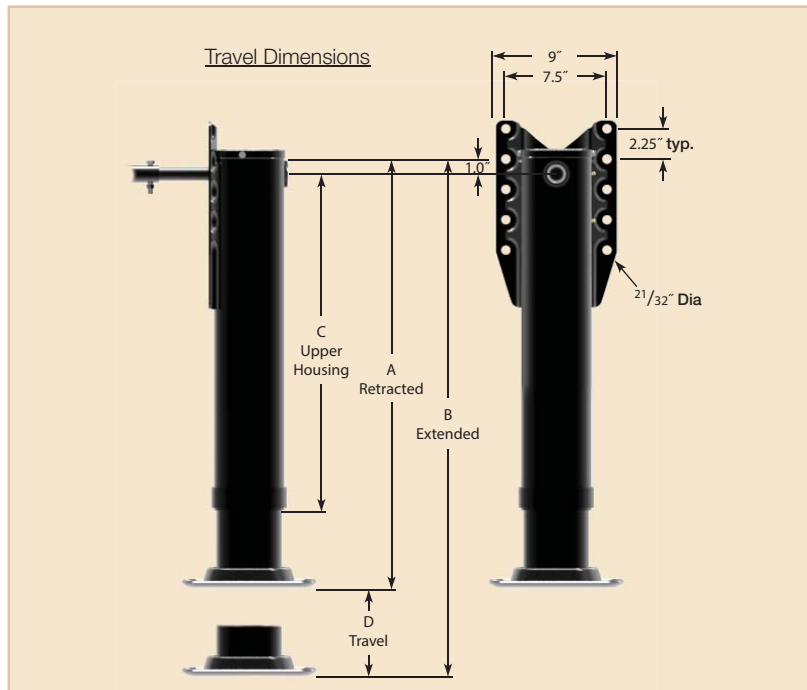
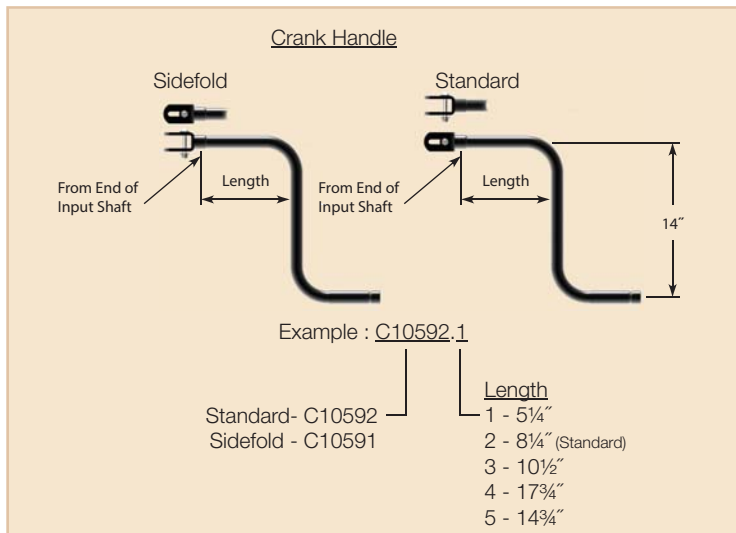
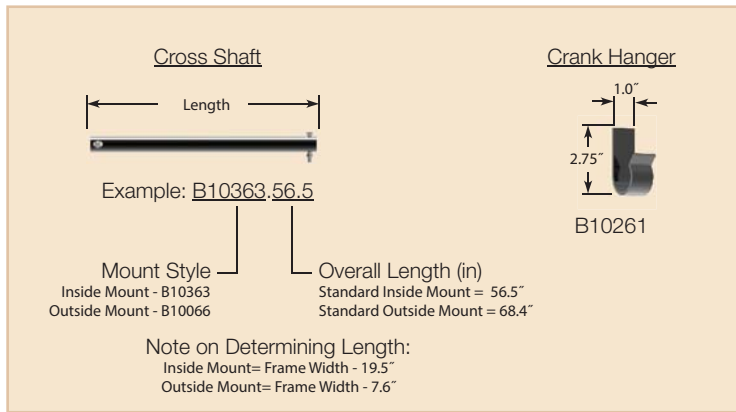
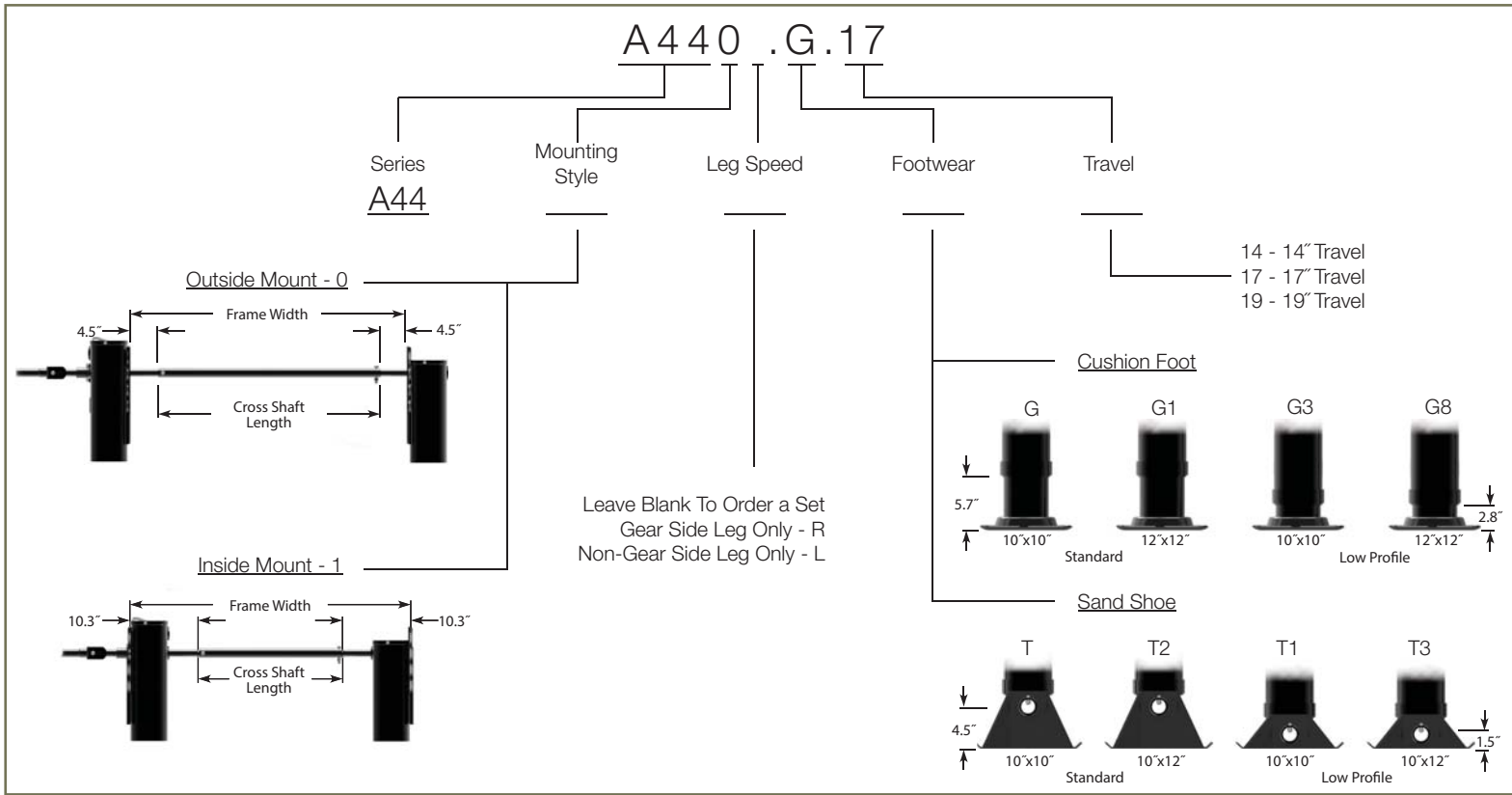

D Travel	Shoe Style						C Upper Hsg.
	T, T2, G, G1		T1, T3		G3, G8		
	Extended	Retracted	Extended	Retracted	Extended	Retracted	
14	42 5/8"	28 5/8"	40 1/8"	26 1/8"	39 3/4"	25 3/4"	21 15/16"
17	48 5/8"	31 5/8"	46 1/8"	29 1/8"	45 3/4"	28 3/4"	24 15/16"
19	52 5/8"	33 5/8"	50 1/8"	31 1/8"	49 3/4"	30 3/4"	26 15/16"